

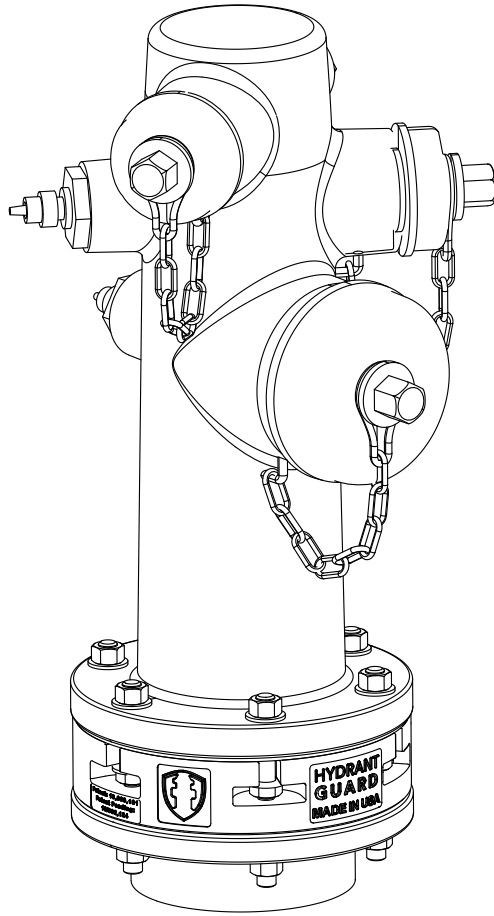

INSTALLATION INSTRUCTIONS - HG1

Hydrant Guard® Stainless Steel Dual Plate Check Valve
For Wet Barrel Fire Hydrants

Form HG1-II



DRAWINGS NOT TO SCALE

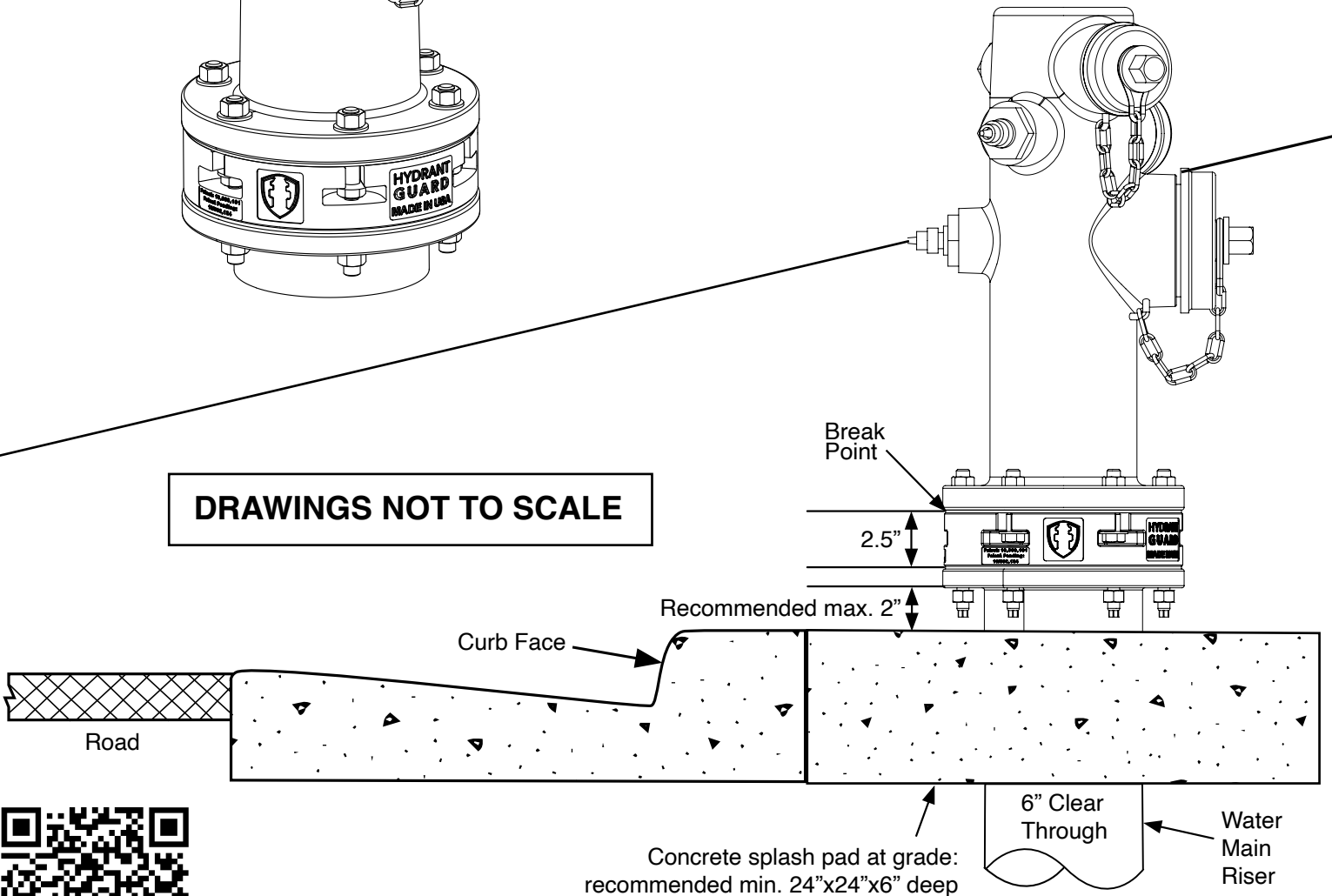

SCAN FOR
LATEST VERSION





INSTALLATION INSTRUCTIONS - HG1

Hydrant Guard® Stainless Steel Dual Plate Check Valve
For Wet Barrel Fire Hydrants

Form HG1-II

Package Contents
As Shipped

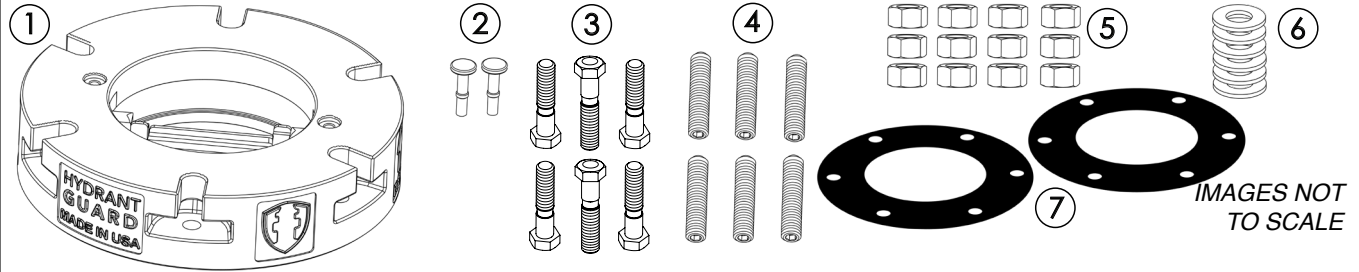

IMAGES NOT TO SCALE



- **TIGHTEN BREAKAWAY BOLTS TO 50 FT-LBS.**
- **USE AN ANSI-APPROVED STAR TIGHTENING PATTERN TO TIGHTEN BREAKAWAY BOLTS.**
- **DO NOT USE IMPACT WRENCHES TO TIGHTEN BREAKAWAY BOLTS.**
- **WASHERS BELOW THE WATER MAIN FLANGE ARE OPTIONAL. BREAKAWAY-BOLT WASHERS ARE REQUIRED.**
- **DO NOT INSTALL HYDRANT GUARD ABOVE ANY ENGINEERED BREAK POINTS.**

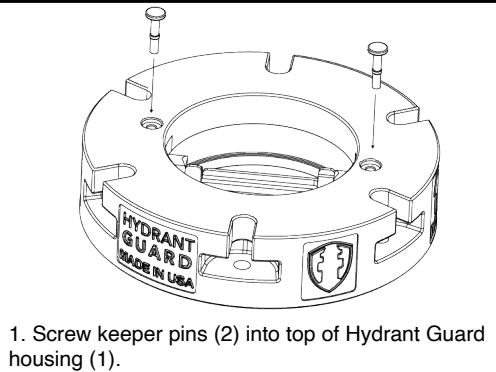
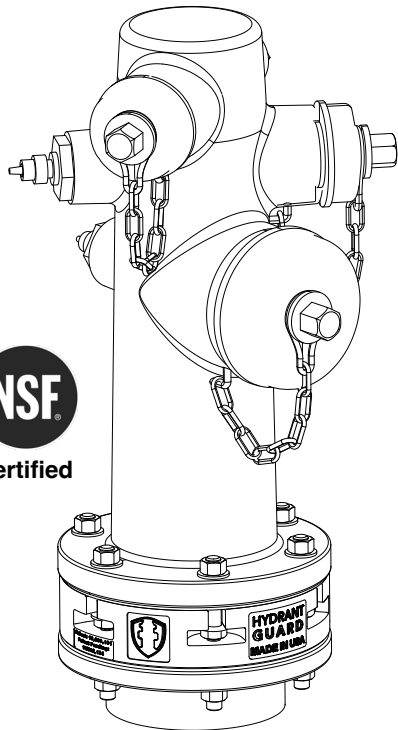

1. Screw keeper pins (2) into top of Hydrant Guard housing (1).

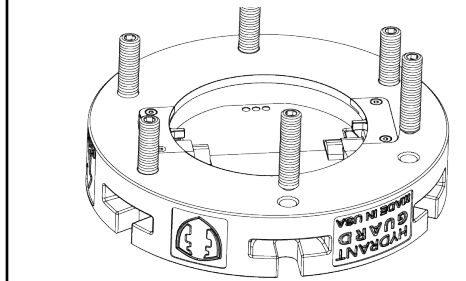

2. Screw 5/8"-11 mounting studs with 5/16" hex heads (4) into bottom of Hydrant Guard housing (1). Make sure that bolts bottom out in the hole.

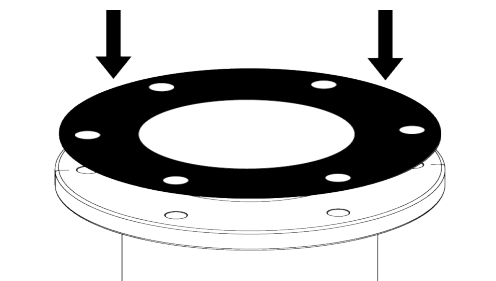

3. Ensure that the flange is clean and clear of any debris, then place full-face gasket (7) on water main flange.

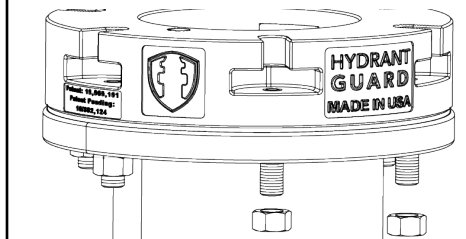

4. Set Hydrant Guard housing (1) onto gasket. Install washers (6 - optional) and nuts (5) to attach Hydrant Guard housing (1) to water main flange. **Use an ANSI-approved star pattern** to tighten nuts until they form a tight seal.

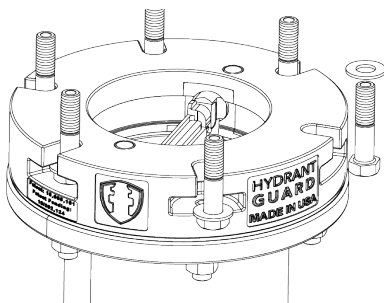

5. Slide Hydrant Guard Breakaway Bolts (3) with washers (6 - required) into side slots of Hydrant Guard housing (1).

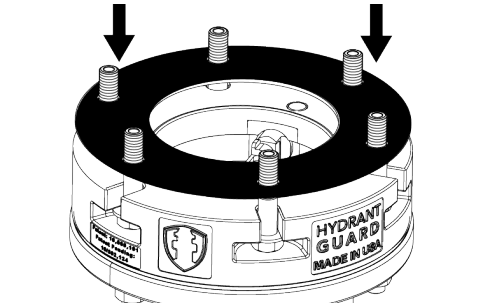

6. Install top gasket (7) onto Hydrant Guard housing (1).

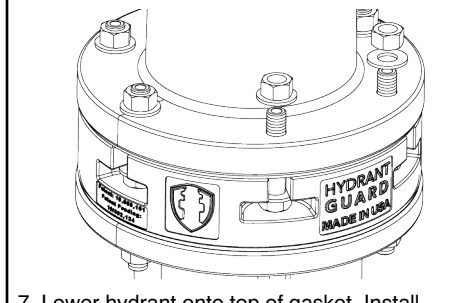

7. Lower hydrant onto top of gasket. Install remaining washers (6 - optional) and nuts (5). Hand torque nuts (5) onto breakaway bolts (3) to **50 ft-lbs using an ANSI-approved star tightening pattern.**

For installation support, contact your local Hydrant Guard rep or call (213) 291-9109

For warranty information visit www.hydrantguard.com/warranty